

Single door upright ice storage bins with SmartGATE® ice shield

SG Series

**Easy to clean, corrosion-resistant ABS/poly tops!
Lifetime cabinet and liner warranty!**



Model SG1475-60

Poly ice access door assembly

- No sharp corners
- Saves aisle space – only 8" (204 mm) deep
- Removes with only 4 screws, no sealant



Safely loosen congealed ice **through** SmartGATE ice shield with optional ice paddle accessory. Released ice remains **behind** SmartGATE ice shield.

Only **SmartGATE** ice shield positively controls ice flow into access door area for increased safety, reduced spillage.

Ice storage bins with industry-exclusive SmartGATE ice shield. For use with all major commercial icemakers. Complete stainless exterior standard, including stainless back and bottom. All bins include corrosion-resistant ABS/poly top† custom cut for icemaker(s), 82 oz plastic ice scoop, and 6" (153 mm) stainless steel adjustable legs.

† All ice storage products include top cut to accommodate specified icemaker. Orders can not be processed without complete manufacturer name and model number. Please specify at time of order.

Wide range of sizes to meet varied needs

- Twelve models in widths from 30" to 60" (762 mm to 1524 mm) and capacities from 460 lbs to 1660 lbs (209 kg to 753 kg)

Industry-exclusive inner SmartGATE ice shield delivers more safety, less spillage

- First ice in is first ice out
- Positively controls ice flow into access door area for easy removal with either scoop or shovel
- Allows loosening of congealed ice without lifting gate for increased safety and reduced spillage
- Locks open in 3 positions
- Returns easily to full down position even when bin is full

Durable polyethylene lift doors with PowerHinge™ door hinge

- Doors stay safely open – no door catches
- No sharp corners to injure workers
- Molded-in gasket never needs to be replaced
- Easy one-hand open and close

Poly ice access door assembly

- Withstands heavy abuse
- Eliminates rusting and corrosion

Non-corroding poly liners, top and trim

- Eliminates pitting and staining from released chlorine
- Makes cleaning easy

Other quality construction features

- Heavy-duty welded construction
- Non-CFC foamed-in-place insulation
- Translucent double-wall poly windows

Optional accessories (refer to form# 3435)

- SmartCART™ 75 ice cart with 3 Totes™ ice carriers
- Ice paddle and hanging bracket (item# ABICEPADDL46)
- Plastic shovel (item# ABICSHOVEL)
- San Jamar Saf-T-Ice* Guardian scoop system (item# 00146365)
- Drain pan (required for some Vogt and Howe icemakers; consult factory)
- 6" (153 mm) stainless legs with flanged feet (item# ABSPECLEG3)
- 10" (254 mm) stainless legs (item# 00151647)
- Centered bin partition
- Flexi-Tops™ ice bin top system for 48" (1220 mm) and 60" (1524 mm) wide models (refer to form# 3435)

* Saf-T-Ice is a registered trademark of San Jamar, a division of the Coleman Group, Inc. in the United States.

JOB: _____
ITEM: _____

U.S. Patent 5,797,514 and 5,887,758

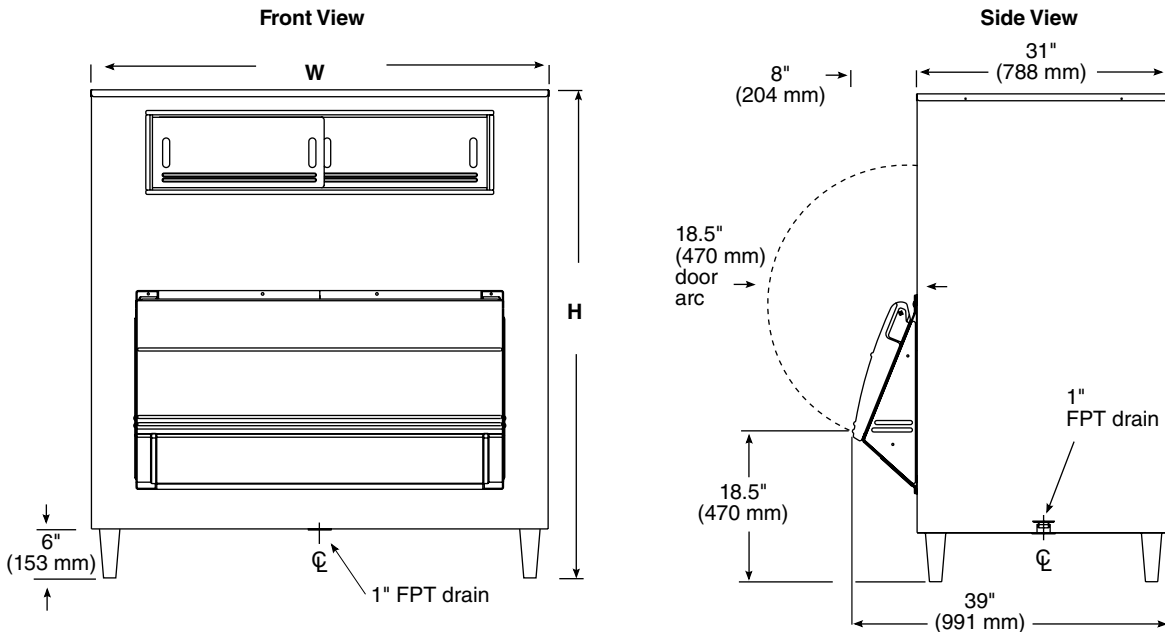

General Notes

Follett recommends installation of a floor drain with grate with all ice storage bins.

Model Number	Cubic Volume cu ft (m)	Max. Bin Capacity lb (kg) ¹	Width (W) in (mm)	Height (H) with Legs in (mm) ⁵	Req'd Door Access in (mm) ^{3,4}	Approx. Ship Weight lb (kg) ²
SG500S-30	14.8 (0.41)	460 (209)	30 (762)	44.5 (1131)	31 (788)	177 (80)
SG700S-30	21.7 (0.61)	680 (308)	30 (762)	60.0 (1524)	31 (788)	207 (94)
SG860S-48	19.7 (0.56)	860 (390)	48 (1220)	46.5 (1181)	32 (813)	275 (125)
SG1010S-48	31.9 (0.90)	1000 (454)	48 (1220)	56.0 (1423)	32 (813)	276 (126)
SG1175S-48	37.6 (1.06)	1185 (538)	48 (1220)	62.0 (1575)	32 (813)	287 (131)
SG1300S-48	41.9 (1.19)	1320 (599)	48 (1220)	65.0 (1651)	32 (813)	300 (137)
SG1160S-56	37.3 (1.06)	1170 (531)	56 (1423)	56.0 (1423)	32 (813)	293 (133)
SG1350S-56	43.2 (1.22)	1360 (617)	56 (1423)	62.0 (1575)	32 (813)	322 (147)
SG1080S-60	34.3 (0.97)	1080 (490)	60 (1524)	46.5 (1181)	32 (813)	202 (92)
SG1325S-60	42.0 (1.19)	1325 (601)	60 (1524)	56.0 (1423)	32 (813)	320 (146)
SG1475S-60	47.4 (1.34)	1490 (676)	60 (1524)	62.0 (1575)	32 (813)	330 (150)
SG1650S-60	52.8 (1.50)	1660 (753)	60 (1524)	65.0 (1651)	32 (813)	350 (159)

Notes:

- 1 Computed on cubic volume of bin. Does not reflect cart capacity or voids that can occur due to pyramiding.
- 2 Add 2" (51 mm) to depth and 10 lbs (4.5 kg) to shipping weight when drain pan accessory used.
- 3 Door assemblies remove easily (4 screws, no sealant) if required for installation access.
- 4 Required clearance for installation access through doors (may require removal of door assembly).
- 5 Special top required for icemakers weighing more than 1000 lbs (454 kg). Add 2.125" (54 mm) to height. Contact factory.

Warranty

- The cabinet exterior, including top and trim, and the interior liner will remain free of corrosion for the useful life of the product.
- Doors, inspection windows, ice gates, and all other integral components are covered against defects in material or workmanship for five years from date of installation. Installation date shall not exceed 90 days from date of shipment.
- Ice transport carts, scoops, paddles, shovels, rakes and other accessories are covered against defects in material or workmanship for two years from date of installation. Installation date shall not exceed 90 days from date of shipment.

Specifications

Ice storage bin to be Follett model _____ with industry-exclusive SmartGATE ice shield. Cubic capacity to be _____, to hold approximately _____ lbs (kg) of ice. Construction to be welded steel shell and frame. Exterior finish to be stainless steel front, sides, back and bottom. Bin liner to have non-corroding polyethylene walls and stainless steel bottom. Bin insulation to be non-CFC polyurethane foam, bonded to shell and liner for added structural strength. Bin top to be ABS plastic custom cut for specific icemaker(s) to be used. Lower door assembly to include non-corroding poly snout, poly lift door with PowerHinge door hinge to eliminate gasket and latches, and inner SmartGATE ice shield to positively control ice flow into snout area and reduce spillage. Entire lower door assembly to be easily removable for installation through narrow doors. Upper inspection windows to be of molded double-wall plastic to increase durability and minimize meltage and condensation. Bin to have 6" (153 mm) legs, adjustable to 7.5". Bin drain to be 1" (26 mm) FPT rigid PVD. Bin to be NSF-listed.

SmartCART, PowerHinge and Totes are trademarks of Follett Corporation.
 SmartGATE is a registered trademark of Follett Corporation, registered in the US.
 Follett reserves the right to change specifications at any time without obligation. Certifications may vary depending on country of origin.